

# Students' Perceptions of Doing the Same English Project Again

Vladimir Román Gutiérrez- Huancayo  
Universidad César Vallejo, Piura, Perú

**Abstract**—Peruvian schooling has several problems. Unquestionably, one of them is the physical layout and infrastructure of the classrooms, which impedes the appropriate development of the curriculum. How would the pupils feel if they had to redo an English language learning activity? The current study examines the feelings of a group of students from a technological institute regarding retaking the same assignment from a recently completed English course. The influence of three constructs—Resilience (R), Psychological Aspects (PA), and Learned Competencies (LC)—on the Do It Again Project (DA) was assessed using a Structural Equation Model (SEM). This SEM was developed based on the validity and reliability of the fit provided by an exploratory factor analysis (EFA) and a confirmatory factor analysis (CFA). One of the most noteworthy results was that R (timely preparation, keeping a positive attitude, and having the support of family and friends) and PA (motivation, self-esteem, and creativity) have a positive and significant influence on the likelihood of repeating the same activity. However, there is no detectable effect of LC on DA, which is viewed as a sign that, should the same study be repeated, there would be nothing more to discover.

**Index Terms**—do again, resilience, factorial analysis, structural equation modeling (SEM)

## I. INTRODUCTION

There is considerable evidence that the quality and characteristics of the environments in which students engage in their academic experiences can influence the achievements and learning outcomes they attain. Shmis et al. (2020) argue that various elements such as lighting, ventilation, desk arrangement, and even noise in the space can influence students' learning. Thus, the comfort of an educational space motivates the academic content to be highly achievable. According to Yangambi (2023), two crucial elements in students' academic success are the physical attributes of study spaces and the skills involved in the teaching and learning process. Accordingly, the author concludes that these two elements can significantly impact the persons' remaining lives and future education. According to Díaz-Parra et al. (2022), the current trend is to support educational environments that integrate interactive programs and technology, reflecting modernity in the teaching and learning process. That is, a higher number of relevant learning experiences will be made possible by the nearly constant usage of the internet, apps, and software; on the other hand, their absence will doom educational institutions to impending obsolescence. The high student-teacher ratio, incomplete learning, student plagiarism, and a glaring lack of gender equality in education are just a few of the issues that arise in any third-world nation when there are physical infrastructure problems in educational institutions, as Memon (2007) explains. In this sense, the question arises: what can be done to make students feel comfortable and motivated in class, even when the physical infrastructure and facilities are inadequate? One potential explanation is the concept of educational resilience, which enables students to achieve the set academic objectives and even complete the semester. To achieve educational resilience, Calhoun et al. (2019) outline the tactics that need to be established. These tactics are closely tied to the didactic and pedagogical work conducted in the classroom, which creates an environment that facilitates effective communication between instructors and students, ultimately leading to good academic outcomes. This "internal support" includes continuing emotional and psychological assistance in addition to the assessment of academic performance. The writers also state that outside assistance from students' friends and family is unquestionably another cornerstone that makes these programs effective. In light of these reasons, we need to consider if students might have the same educational experience again in the absence of proper physical infrastructure. According to Huancayo (2024), assignments and projects should be developed based on the interests of the students—that is, activities where the core of the previously stated performances typically aligns with their personal and professional objectives. The second query is whether a student may retake the same assignment or learning project in the same setting to improve their English skills. The method of repeating words and phrases is well known for learning the English language. According to Wirawan (2019), the purpose of repeating key points from the prior explanations is to help students retain the information and comprehend the material in the upcoming lesson. According to Stone et al. (2013), several prerequisites are necessary for the teaching-learning process to be successful when employing the repetition approach. First, re-examining previously covered material facilitates a revisit to the subject. Second, the learner needs to be reminded of these topics in a different way, using other examples or scenarios. Third, it should not take too long so that the following material may be learnt.

Let us now position ourselves within the framework of the current study. Firstly, it is worth noting that precarious conditions of physical infrastructure are widespread in Peru. In this developing country, two prevalent problems with the physical infrastructure of public education are evident. The first is that a large number of educational institutions have classrooms that lack adequate furniture, basic services, and other conveniences. The other scenario is when the institutions are under reconstruction, as is the case with the institution where the present study was conducted. The third and last question is whether it is feasible to teach and learn English using the same project and assignments in these conditions. Thus, in the current study, students who just finished the English course project—which was accomplished in classrooms with shaky infrastructure—were asked if they would have to retake it, this is due to the existence of very few precedents in which this is consulted, that is, what the students think about experiencing the same learning experience again and with the same poor infrastructure conditions of the classrooms.

## II. METHODOLOGY

The main objective of this study was to understand how a group of higher education students perceived the possibility of undertaking an English language project again, which was carried out under challenging conditions. To this end, 65 of the 73 students who initially participated in the project completed a survey that included four latent variables (learned competencies, psychological aspects, resilience, and motivation), each with 5 or 6 observable variables. Subsequently, the relationship of these latent variables was measured through a Structural Equation Model (SEM). It is for all the aforementioned reasons that we can affirm that the present study used a quantitative approach with a non-experimental design.

We can formulate the following queries and hypotheses in light of the previously mentioned:

P1: Does resilience have a significant impact on the hypothetical situation of repeating the same project?

P2: Would psychological factors have a significant impact on the hypothetical situation of repeating the same project?

P3: Would the hypothetical situation of completing the same project again be significantly impacted by the Learned Competencies?

H01: The fictitious situation of starting the same project over is significantly impacted by resilience.

H02: In the hypothetical situation of starting the same project over, psychological factors have a significant impact.

H03: The Learnt Competencies have a significant impact on the fictitious situation of completing the same project again.

### Sample and Sampling

In the present study, 65 students from three professional programs (industrial chemistry, production mechanics, and electricity) participated in a survey administered at the end of the semester project in the English course. In this way, 29 (44.6%), 21 (32.3%), and 15 (23.1%) belonged to the majors as mentioned earlier in order, as mentioned above. Of the total mentioned, 47 (72.3%) were men and 18 (27.7%) were women. Additionally, their ages ranged from 16 to 42 years, and at the time of this study, they were in their third semester of professional degree studies. It is worth noting that the sampling was non-probabilistic, based on 73 students who participated in the semester project of the English course.

### Description of Study

Initially, 73 students from three professional programs (industrial chemistry, production mechanics, and electricity) participated in designing a video that addressed a topic related to their profession (Appendix A). These projects were carried out in very precarious environments or with deficiencies in equipment and infrastructure. Although there was indeed a noticeable improvement in productive abilities at the end of the project (Appendix B), this study's primary goal was different. At the end of this experience, 64 out of the total mentioned above responded to a survey, which had the sole objective of understanding their perceptions in a scenario where they had to repeat this academic experience, under the same infrastructural conditions of the educational institution (Appendix C).

### Research Instrument

The instrument chosen for the present research was a survey. The author created it after reading the theory put forward by Koyama (2015), who clarifies that people can learn English, despite the difficulties, as long as this learning brings improvements to their daily lives, mainly in their work. On the other hand, the theory proposed by Christopher and Peck (2004) suggests that resilience is learned in complex spaces and moments, as long as there is ongoing communication between the components of the teaching-learning process. In this way, students and teachers become aware of the importance of shared content, which in turn promotes continuous interaction between them, allowing for an understanding of the former's difficulties and providing support and monitoring from the latter. Finally, the design of the present survey was also based on the proposal by Astawa et al. (2017), who suggest that productive competencies in the English language are closely related to the development of tasks and projects in the classroom, which in turn are related to the context and interests of the students. This survey consisted of two segments. The first was to collect sociodemographic information (professional career, gender, and age). The second one consisted of 23 items with Likert-type alternatives at the time of responding. In this way, the possible responses ranged from 5 points for 'completely agree' to 1 for 'completely disagree'. Here were included: 4 (agree), 3 (neutral), and 2 (disagree). This part consisted of four constructs or latent variables: Learned Competencies (LC), Psychological Aspects (PA), Resilience (R), and Doing It Again (DA). Likewise, six observable variables were considered for the first three latent variables and five observable

variables for the last one. This survey was designed in Google Forms and shared with the students through the group WhatsApp. Additionally, it was anonymous and written in Spanish, the students' native language, to promote easy and quick completion. The data collection took place between the second week of December last year and the first week of this year.

#### Data Analysis

The analysis of the data collected in the present study, through the previously described survey, had three phases. Initially, the SPSS version 27 program was used. Here, reliability was measured using Cronbach's Alpha and an Exploratory Factor Analysis (EFA). Both figures indicate the feasibility of proceeding with the next step, which involves a Confirmatory Factor Analysis (CFA). Once the validity of the CFA is established through fit indices such as CFI, TLI, IFI, RNI, and RMSEA, we can proceed to the final phase, which involves obtaining a Structural Equation Model (SEM). This will provide insight into the relationship between the aforementioned latent variables. To carry out these last two procedures (CFA and SEM), the statistical program JASP was used.

### III. RESULTS

Among the most notable results of the first stage are a Cronbach's alpha of 0.98 and adequate EFA values: a Kaiser-Meyer-Olkin (KMO) measure of 0.90 and Bartlett's Test of Sphericity, also within the appropriate parameters (chi-square approximation of 1111.233, df of 253, and significance < 0.001). These initial results allow us to proceed to the next stage, the CFA. According to Tavakol and Dennick (2011), the value obtained in the Cronbach's alpha is appropriate, thus demonstrating the reliability of the survey in the present study. Likewise, a KMO of 0.90, as is the case here, reflects the adequacy of the sample. At the same time, the Bartlett's Test of Sphericity, with a p-value of 0.001 (less than 0.05), indicates that the variables are correlated and suitable for investigating underlying causes (Shrestha, 2021).

Regarding the CFA, the following items were removed: 2, 12, 16, 22, and 23, with the sole purpose of ensuring that the model was adequately fitted and allowed for the next step. Next, we will examine the primary adjusted measures of the CFA.

TABLE 1  
MAIN FIT MEASURES

X <sup>2</sup> /df	CFI	TLI	IFI	RNI	GFI	NNFI	RMSEA
1.38	0.930	0.917	0.933	0.930	0.951	0.917	0.077

X<sup>2</sup>: Chi-Square; df: degrees of freedom; CFI: Comparative Fit Index; TLI: Tucker Lewis Index; IFI: Bollen's Incremental Fit Index; RNI: Relative Noncentrality Index; GFI: Goodness of Fit Index; NNFI: Bentler-Bonett Non-normed Fit Index; RMSEA: Root Mean Square Error of Approximation.

The position of Goretzko et al. (2024) is that a must be less than 3, which demonstrates that the model has a generally adequate fit. At the same time, the following measures, such as CFI, TLI, IFI, RNI, and NNFI, must be greater than 0.9, ensuring that each of the constructs, also referred to as latent variables, is correctly validated. On the other hand, RMSEA values less than 0.08 are considered adequate. Based on the previously mentioned information and the results presented in the previous table, this model, considering its CFA, is adequate.

TABLE 2  
VALIDITY AND RELIABILITY OF OBSERVABLE VARIABLES

Resilience	Indicator	Factor load	KMO	Coefficient $\alpha$	Coefficient $\omega$	AVE	CR
I have been able to plan my English project despite the difficulties I have faced.	R1	0.765	0.935	0.897	0.887	0.627	0.976
I have successfully communicated my project to my classmates and professor in English.	R2	0.788	0.866				
I have managed to keep my sense of humor, despite everything, in the execution of the project in English.	R3	0.867	0.913				
I have managed to complete my project thanks to the support of my family and friends.	R4	0.711	0.926				
I have been perseverant despite the difficulties in carrying out this project.	R5	0.817	0.902				
<b>Psychological Aspects</b>							
My motivation to learn English has improved after completing this project.	PA1	0.669	0.934	0.859	0.862	0.557	0.980
My fear of speaking English in front of people has decreased after completing this project.	PA2	0.779	0.941				
My willingness to learn English has increased after completing this project.	PA3	0.735	0.872				
My self-esteem has increased after completing this project.	PA4	0.80	0.886				
My creativity has increased after completing this project.	PA5	0.743	0.887				
<b>Learned Competences</b>							
I have learned a great deal of vocabulary related to my career thanks to this project.	LC1	0.722	0.906	0.880	0.880	0.596	0.973
I have learned to write better terms related to my career, thanks to this project.	LC2	0.772	0.949				
I have learned to prepare an oral presentation, thanks to this project.	LC3	0.706	0.864				
I have learned to prepare and select material to present in my English video, thanks to this project.	LC4	0.854	0.917				
I have learned to create material in line with my presentation in the video.	LC5	0.813	0.858				
<b>Do again</b>							
I would undertake a project like this in English again, despite the difficulties that may arise.	DA1	0.748	0.873	0.787	0.787	0.554	0.98
I would give an oral presentation in English again in front of an audience.	DA2	0.749	0.863				
I would do a project like this again in another course.	DA3	0.734	0.900				

Coefficient  $\alpha$ : Coefficient alpha of Cronbach; Coefficient  $\omega$ : Coefficient omega of McDonald; AVE: Average Variance Extracted; CR: Composite Reliability

The four latent variables (R, PA, LC, and DA) and their corresponding observable variables are shown in the preceding table. For instance, five observed variables were considered for LC, five more for PA, five more for R, and only three for DA. Regarding the load factors, as determined by Auerswald and Moshagen (2019), the relationship between the observed and latent variables yields figures ranging from 0.669 to 0.854, providing insight into the suitability of the model described. According to established norms, the KMO, a measure of the sampling's adequacy, falls between 0.858 and 0.941, which are extremely sufficient indices (Mosly, 2015). Conversely, each latent variable's internal consistency is represented by the coefficients  $\alpha$  and  $\omega$ . The numbers in this instance, which fall between 0.787 and 0.897, are deemed sufficient (Osburn, 2000). Lastly, the quality and consistency of the constructs included in the developed model are measured by AVE and CR. The values in the second must be more than or equal to 0.7, while the values in the first must be bigger than or equal to 0.5. The values for AVE and CR in the current study range from 0.554 to 0.627 and 0.973 to 0.980, respectively. This suggests that the latent variable's variance in the first case and the model's internal consistency in the second case are both highly suitable for the goals of the current investigation (Carter, 2016). The following section of the assessment of the suggested model focuses on discriminant validity, which was used to confirm the degree of similarity between the latent variables.

TABLE 3  
HETEROTRAIT-MONOTRAIT RATIO

	CL	PA	R	DA
CL	---			
PA	0.832	---		
R	0.825	0.814	---	
DA	0.715	0.795	0.803	---

It is evident from the findings of HTMT that there is no discriminant validity among the latent variables, indicating that each one is an independent or distinct component from the others. This is based on the results (less than 0.9) (Henseler, 2017).

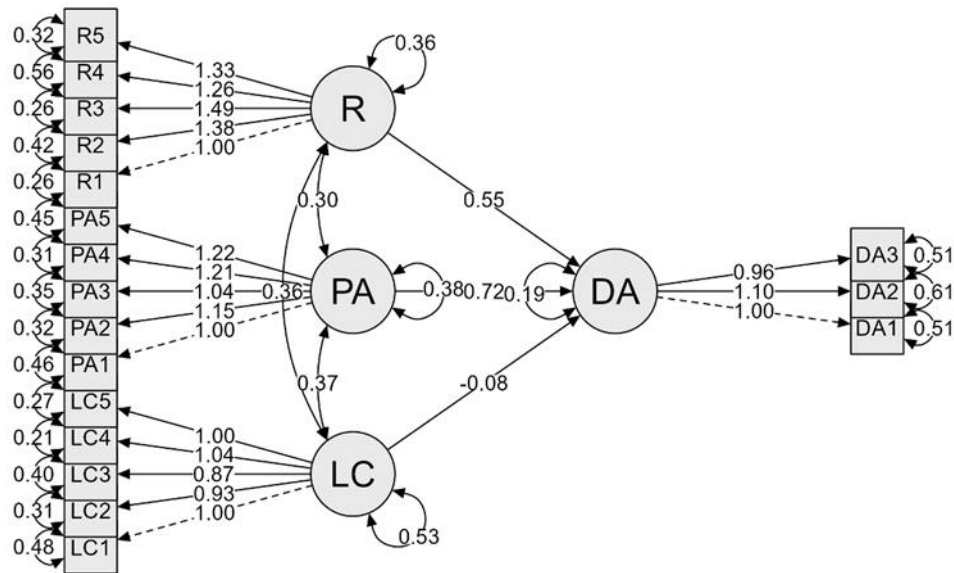

Figure 1. Path Analysis

In the graph above, we can observe a positive and significant interrelationship between the latent variables R and DA (0.55). This suggests that resilience may be a key component in a hypothetical situation where the same project is repeated multiple times. Similarly, the case of latent variables PA with DA would be discovered (0.72), indicating that creativity, motivation, and improved public performance may all have a positive and substantial impact on a hypothetical scenario of repeating the project. The relationship between LC and DA (-0.08) is observed in a different scenario, indicating that the skills acquired have a negligible and inverse impact on the likelihood of completing the project again. Thus, we may accept the third null hypothesis (H03) and reject the previous two (H01 and H02) in this section.

IV. DISCUSSION

This study's primary goal is to ascertain the attitudes of students from a Peruvian educational institution on retaking an English project that was developed in volatile learning environments (classrooms, workshops, and laboratories). Therefore, these same students from three professional programs—industrial chemistry, production mechanics, and electricity—were surveyed after finishing a project designed to develop or improve productive skills in the English language (writing and speaking) to find out how they would feel about completing the same project again under the same challenging conditions mentioned above.

The findings from a structural equation model (SEM) that takes into account the relationships between three latent variables—resilience (R), psychological aspects (PA), and learned competencies (LC)—and a fourth latent variable, doing it again (DA), were as follows:

**The hypothetical situation of completing the project again is positively and significantly impacted by resilience.**

It is well established that a student who thinks resiliently prepares for academic activities that help them accomplish their learning-related objectives. According to Tschakert and Dietrich (2010), in addition to preparation, the practical application of coping mechanisms may mediate the completion of school assignments, preventing stress and emotional pain throughout the process. It is also important to remember that planning is a process that helps students adjust to any situation and respond appropriately to any potential academic challenges they may face (Creed et al., 2009).

Conversely, Frisby et al. (2020) outline how resilient settings may be created via consistent and efficient communication between educators and students. In this way, instructors encourage their pupils to seek academic help, and the students themselves experience the same thing. To help other students reach their goals, successful students

work together in collaboration. This is due to the resilient student taking on their classmates' challenges as their own, which starts a positive feedback loop that culminates in the completion of the assigned duties.

Being resilient means maintaining a good mood in the face of complex situations, where the person remains calm and composed, two conditions that facilitate the efficient resolution of the aforementioned situations. According to Mann (2009), the primary cause of happiness encompasses all that has already been described.

Students' resilience, stemming from emotional support from friends and family, is a condition that the student will take for granted, meaning they will always have someone to support them if they ever have to undertake an activity again in challenging or uncomfortable circumstances (Ungar & Hadfield, 2019).

The primary distinction between a resilient and non-resilient pupil is persistence. Through interaction and instructor assistance, Henry et al. (2022) foster competency in the classroom, enabling students to meet all the learning goals established at the start of the semester. Thus, these writers believe that the most crucial emotional competencies that enable the development of human competencies are persistence and tenacity, which go beyond students' cognitive abilities and intellect.

**Some psychological aspects positively influence the imaginary scenario of re-enacting the completed project.**

First, we will discuss how motivation plays a crucial role in learning and completing challenging activities. Stated differently, there is a high likelihood of completing an academic task again, regardless of how challenging it was, if doing so will result in academic and professional advancement (extrinsic motivation) or because the task will enable the completion of a very personal project (intrinsic motivation). For Facione et al. (1996), being capable alone is insufficient; one also needs to be driven and eager to perform particular duties. According to these writers, this concept is consistent with the idea that, despite workers or students possessing exceptional qualifications for their profession, their motivation is determined mainly by their inclination to complete the tasks at hand.

**The hypothetical scenario of completing the same project again is unaffected by the learned competencies (LC).**

Let us start with the findings, which are negative and not statistically significant. This suggests that the students do not believe the LC has any impact on the likelihood of the same project being completed. Let us use Kooloos et al. (2020) as an example, who contend that learning via repetition improves memory and short-term retention. This is precisely why the writers claim that it is essential to review previously learnt material in order to increase understanding of the subject matter. As long as the material being reviewed fosters fresh and significant learning—that is, as long as it is not dull or monotonous—the learned information can encourage repetition as a learning strategy for Brinkmann (2017). As long as the techniques they employ are effective, Wiggins et al. (2021) conclude that the experience of repeating what was learnt in earlier lessons helps them acquire new material. Subsequent laboratory exercises, for instance, help the student realize the significance of grasping particular material before conducting experiments. Nevertheless, we may supplement our understanding with the input of Hanzawa and Suzuki (2023), who believe that it is crucial to reinforce what has been learned, particularly in brief bursts and in a lively and engaging manner. This helps English learners learn more effectively and efficiently without becoming bored or monotonous.

**Limitation**

The main limitation is the sample of students who participated in completing the survey. According to experts, the recommended quantity is 200 units.

## V. CONCLUSIONS

The first finding of the current study is that students who complete an English project under challenging infrastructural conditions may be able to do it again in the future due to their resilience. Second, psychological factors, including inspiration, inventiveness, increased self-worth, and a reduction in public speaking anxiety, might also encourage repeating the previously described educational experience. Third, it appears that the teaching-learning process might become monotonous and boring, so the knowledge gained from the same experience is not enough justification for repeating the same endeavor.

## APPENDIX A. SCREENSHOT OF THE VIDEOS CREATED BY THE STUDENTS AND THEN UPLOADED TO THE CLASSROOM



## APPENDIX B. RESULTS OF PRODUCTIVE SKILLS

TABLE 4  
WRITING SKILLS BEFORE AND AFTER THE PROGRAM

Criteria	Test	Mean± Std	t	Sig.	Cohen's d
Grammar	Pretest	0.479±0.503	-31.910	<.001	0.774
	Posttest	3.369±0.513			
Vocabulary	Pretest	0.589±0.495	-32.901	<.001	0.726
	Posttest	3.389±0.543			
Organization	Pretest	0.452±0.501	-31.557	<.001	0.796
	Posttest	3.397±0.571			
Content	Pretest	0.287±0.291	-39.919	<.001	0.633
	Posttest	3.246±0.464			

TABLE 5  
SPEAKING SKILLS BEFORE AND AFTER THE PROGRAM

Criteria	Test	Mean± Std	t	Sig.	Cohen's d
Pronunciation	Pretest	0.863±0.508	-30.031	<.001	0.740
	Posttest	3.465±0.502			
Vocabulary	Pretest	0.684±0.523	-33.021	<.001	0.744
	Posttest	3.561±0.499			
Grammar	Pretest	0.767±0.457	-33.504	<.001	0.685
	Posttest	3.452±0.501			
Speech	Pretest	0.753±0.493	-29.774	<.001	0.755
	Posttest	3.383±0.489			

## APPENDIX C. PHYSICAL CONDITION OF THE CLASSROOMS



## ACKNOWLEDGMENTS

The pupils of the Almirante Miguel Grau Higher Technological Institution in Piura, Peru, are sincerely appreciated. Throughout this investigation, students from various engineering disciplines, including industrial, chemical, electrical,

and mechanical engineering, were actively engaged.

#### REFERENCES

- [1] Astawa, N. L. P. N. S. P., Artini, L. P., & Nitiasih, P. K. (2017). Project-based learning activities and EFL students' productive skills in English. *Journal of Language Teaching and Research*, 8(6), 1147. <https://doi.org/10.17507/jltr.0806.16>
- [2] Auerswald, M., & Moshagen, M. (2019). How to determine the number of factors to retain in exploratory factor analysis: A comparison of extraction methods under realistic conditions. *Psychological Methods*, 24(4), 468–491. <https://doi.org/10.1037/met0000200>
- [3] Brinkmann, M. (2017). Repetition and transformation in learning. In *SensePublishers eBooks* (pp. 73–83). [https://doi.org/10.1007/978-94-6300-797-9\\_6](https://doi.org/10.1007/978-94-6300-797-9_6)
- [4] Calhoun, Y., Snodgrass Rangel, V., & Coulson, H. L. (2019). Educational Resilience at Risk? The Challenges of Attending an Early College High School. *The Urban Review*, 51(2), 301–325. <https://doi.org/10.1007/s11256-018-0481-x>
- [5] Carter, S. R. (2016). Using confirmatory factor analysis to manage discriminant validity issues in social pharmacy research. *International Journal of Clinical Pharmacy*, 38(3), 731–737. <https://doi.org/10.1007/s11096-016-0302-9>
- [6] Creed, P. A., Fallon, T., & Hood, M. (2009). The relationship between career adaptability, person and situation variables, and career concerns in young adults. *Journal of Vocational Behavior*, 74(2), 219–229. <https://doi.org/10.1016/j.jvb.2008.12.004>
- [7] Christopher, M., & Peck, H. (2004). Building the Resilient Supply Chain. *The International Journal of Logistics Management*, 15(2), 1–14. <https://doi.org/10.1108/09574090410700275>
- [8] Díaz-Parra, O., Fuentes-Penna, A., Barrera-Cámara, R. A., Trejo-Macotela, F. R., Ramos-Fernández, J. C., Ruiz-Vanoye, J. A., Zezzatti, A. O., & Rodríguez-Flores, J. (2022). Smart Education and future trends. *International journal of combinatorial optimization problems and informatics*, 13(1), 65.
- [9] Facione, P. A., Facione, N. C., & Giancarlo, C. A. F. (1996). The motivation to think about working and learning. *New Directions for Higher Education*, 1996(96), 67–79. <https://doi.org/10.1002/he.36919969608>
- [10] Frisby, B. N., Hosek, A. M., & Beck, A. C. (2020). The role of classroom relationships as sources of academic resilience and hope. *Communication Quarterly*, 68(3), 289–305. <https://doi.org/10.1080/01463373.2020.1779099>
- [11] Goretzko, D., Siemund, K., & Sterner, P. (2023). Evaluating model fit of measurement models in confirmatory factor analysis. *Educational and Psychological Measurement*, 84(1), 123–144. <https://doi.org/10.1177/00131644231163813>
- [12] Hanzawa, K., & Suzuki, Y. (2023). How do learners perceive task repetition? Distributed practice effects on engagement and metacognitive judgment. *Modern Language Journal*, 107(2), 451–478. <https://doi.org/10.1111/modl.12843>
- [13] Henry, A., Thorsen, C., & Uztosun, M. S. (2022). Exploring language learners' self-generated goals: Does self-concordance affect engagement and resilience? *System*, 112, 102971. <https://doi.org/10.1016/j.system.2022.102971>
- [14] Henseler, J. (2017). Bridging Design and Behavioral Research With Variance-Based Structural Equation Modeling. *Journal of Advertising*, 46(1), 178–192. <https://doi.org/10.1080/00913367.2017.1281780>
- [15] Huancayo, V. R. G. (2024b). Learn oral skills keeping in mind the issues of interest. *Theory and Practice in Language Studies*, 14(10), 3028–3036. <https://doi.org/10.17507/tpls.1410.03>
- [16] Kooloos, J. G. M., Bergman, E. M., Scheffers, M. A. G. P., Schepens-Franke, A. N., & Vorstenbosch, M. A. T. M. (2020). The Effect of Passive and Active Education Methods Applied in Repetition Activities on the Retention of Anatomical Knowledge. *Anatomical Sciences Education*, 13(4), 458–466. <https://doi.org/10.1002/ase.1924>
- [17] Koyama, J. (2015). Learning English, working hard, and challenging risk discourses. *Policy Futures in Education*, 13(5), 608–620. <https://doi.org/10.1177/1478210315579547>
- [18] Mann, S. (2009). Tim Jackson, Prosperity without Growth: Economics for a Finite Planet (London: Earthscan, 2009). *Yearbook of International Environmental Law*, 20(1), 889–893. <https://doi.org/10.1093/yiel/20.1.889>
- [19] Memon, G. R. (2007). Education in Pakistan: The Key Issues, Problems and The New Challenges. *Journal of Management and Social Sciences*, 3(1), 47–55.
- [20] Mosly, I. (2015). Safety Performance in the Construction Industry of Saudi Arabia. *International Journal of Construction Engineering and Management*, 4(6), 238–247. <https://doi.org/10.5923/j.ijcem.20150406.03>
- [21] Osburn, H. G. (2000). Coefficient Alpha and Related Internal Consistency Reliability Coefficients. *Psychological methods*, 5(3), 343.
- [22] Shmis, T., Ustinova, M., & Chugunov, D. (2020). *Learning environments and learning achievement in the Russian Federation: How school infrastructure and climate affect student success*. World Bank Group.
- [23] Shrestha, N. (2021). Factor Analysis as a Tool for Survey Analysis. *American Journal of Applied Mathematics and Statistics*, 9(1), 4–11. <https://doi.org/10.12691/ajams-9-1-2>
- [24] Stone, L. L., Otten, R., Janssens, J. M. A. M., Soenens, B., Kuntsche, E., & Engels, R. C. M. E. (2013). Does parental psychological control relate to internalizing and externalizing problems in early childhood? An examination using the Berkeley puppet interview. *International Journal of Behavioral Development*, 37(4), 309–318. <https://doi.org/10.1177/0165025413490865>
- [25] Tavakol, M., & Dennick, R. (2011). Making sense of Cronbach's alpha. *International Journal of Medical Education*, 2, 53–55. <https://doi.org/10.5116/ijme.4dfb.8dfd>
- [26] Tschakert, P., & Dietrich, K. A. (2010). Anticipatory Learning for Climate Change Adaptation and Resilience. *Ecology and Society*, 15(2), 11. <https://doi.org/10.5751/ES-03335-150211>
- [27] Ungar, M., & Hadfield, K. (2019). The differential impact of environment and resilience on youth outcomes. *Canadian Journal of Behavioural Science / Revue Canadienne Des Sciences Du Comportement*, 51(2), 135–146. <https://doi.org/10.1037/cbs0000128>
- [28] Wiggins, B. L., Sefi-Cyr, H., Lily, L. S., & Dahlberg, C. L. (2021). Repetition Is Important to Students and Their Understanding during Laboratory Courses That Include Research. *Journal of Microbiology & Biology Education*, 22(2). <https://doi.org/10.1128/jmbe.00158-21>

- [29] Wirawan, I. G. N. (2019). Effect of Repetition Method on Teaching English Process in Classroom. 3(3). *International journal of social sciences and humanities*, 3(3), 143-146.
- [30] Yangambi, M. (2023). Impact of School Infrastructures on Students Learning and Performance: Case of Three Public Schools in a Developing Country. *Creative Education*, 14(04), 788-809. <https://doi.org/10.4236/ce.2023.144052>



**Vladimir Román Gutiérrez-Huancayo** is a pharmacist and educator born in Paita, Peru. For several years, he has been working as a teacher-researcher at César Vallejo University, while also promoting English for Specific Purposes (ESP) at a public higher education institution.